

PASS-THROUGH HANDLE SHANKS

Glass-fibre reinforced polyamide based (PA) technopolymer, matte finish.

To prevent tube rotation, screw up to the stop the self-tapping screw $\varnothing 3,9 \times 6,5$ arranged inside the handle shank.

CLOSING CAPS

- ECS.T: polyamide based (PA) technopolymer, in the colours specified in the standard executions, matte finish, press-fit assembly (Fig.1): Supplied, removable by a screwdriver.

Available also as accessory sold separately (see table).

END CAPS

Polyamide based (PA) technopolymer, matte finish.

MOUNTING

Pass-through hole for front or rear mounting by means of cylindrical-head screws with hexagon socket, hexagonal-head screws or standard nuts.

STANDARD EXECUTIONS

- **M.1053-P-EP:** aluminium tube, epoxy resin coating, metallflake graphite colour, matte finish. Highly resistant to wear, scratches and chemical agents. Avoid continuous and prolonged contact with boiling water or steam. Handle shanks and closing caps in RAL 9005 (C9) black colour.
- **M.1053-P-AN-BK:** anodised aluminium tube, natural colour, handle shanks and closing caps in RAL 9005 (C9) black colour.
- **M.1053-P-AN-GR:** anodised aluminium tube, natural colour, handle shanks and closing caps in RAL 7031 (C31) grey colour.
- **M.1053-P-CLEAN:** aluminium tube, coating in white colour similar to RAL 9002, handle shanks and closing caps in white colour similar to RAL 9002 (CLEAN).

TECHNICAL DATA

Tubular handles are characterised by a variable handle shank, the handle shanks being adjustable on the tube by means of the set screw.

Tensile stress: F values reported in the table are the result of breaking tests carried out with the appropriate dynamometric equipment under the test conditions shown in the figure with ambient temperature.

SPECIAL EXECUTIONS ON REQUEST

- Different lengths.

ACCESSORIES ON REQUEST

- ECS.T: polyamide based (PA) technopolymer closing cap, RAL 9005 black colour (C9), RAL 7031 grey (C31), RAL 9002 white, matte finish, press-fit assembly (see table). For sufficient quantities, it can be supplied in other colours.



ELESA Original design

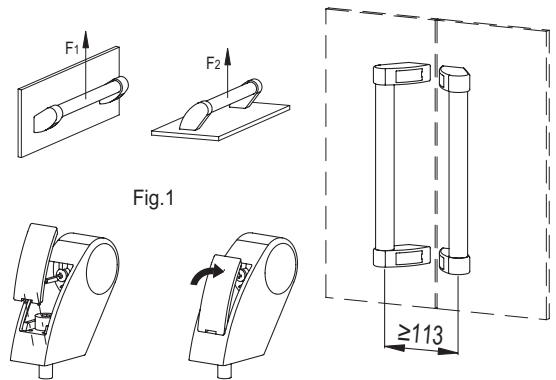

	C9		C31		CLEAN
	RAL9005		RAL7031		RAL9002

ECS.T

Code	Description
29882-C9	ECS.T2-C9
29882-C31	ECS.T2-C31
29882	ECS.T2-CLEAN

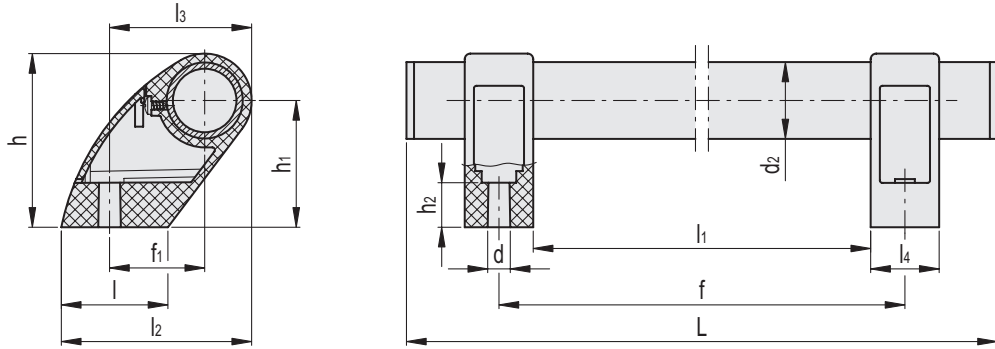

M.1053-P-EP

Code	Description	d2	f _{max.±1}	f1	L	d	h	h1	h2	l	l1 max.	l2	l3	l4	F1 [N]*	F1 [N]#	F2 [N]*	F2 [N]#	⚖
36901	M.1053 P/30-295-EP	30	295	37.5	324	8.5	68.5	50	17.5	42	268	75	56	27	1850	3400	2500	4000	231
36911	M.1053 P/30-345-EP	30	345	37.5	374	8.5	68.5	50	17.5	42	318	75	56	27	1650	3150	2000	3300	249
36921	M.1053 P/30-395-EP	30	395	37.5	424	8.5	68.5	50	17.5	42	368	75	56	27	1450	2600	1900	3000	266
36931	M.1053 P/30-495-EP	30	495	37.5	524	8.5	68.5	50	17.5	42	468	75	56	27	1300	2000	1500	1900	301
36941	M.1053 P/30-595-EP	30	595	37.5	624	8.5	68.5	50	17.5	42	568	75	56	27	1100	1900	1200	1800	336
36951	M.1053 P/30-695-EP	30	695	37.5	724	8.5	68.5	50	17.5	42	668	75	56	27	1000	1600	1100	1500	371

M.1053-P-AN-BK

Code	Description	d2	f _{max.±1}	f1	L	d	h	h1	h2	l	l1 max.	l2	l3	l4	F1 [N]*	F1 [N]#	F2 [N]*	F2 [N]#	⚖
36903	M.1053 P/30-295-AN-BK	30	295	37.5	324	8.5	68.5	50	17.5	42	268	75	56	27	1850	3400	2500	4000	231
36913	M.1053 P/30-345-AN-BK	30	345	37.5	374	8.5	68.5	50	17.5	42	318	75	56	27	1650	3150	2000	3300	249
36923	M.1053 P/30-395-AN-BK	30	395	37.5	424	8.5	68.5	50	17.5	42	368	75	56	27	1450	2600	1900	3000	266
36933	M.1053 P/30-495-AN-BK	30	495	37.5	524	8.5	68.5	50	17.5	42	468	75	56	27	1300	2000	1500	1900	301
36943	M.1053 P/30-595-AN-BK	30	595	37.5	624	8.5	68.5	50	17.5	42	568	75	56	27	1100	1900	1200	1800	336
36953	M.1053 P/30-695-AN-BK	30	695	37.5	724	8.5	68.5	50	17.5	42	668	75	56	27	1000	1600	1100	1500	371

M.1053-P-AN-GR

Code	Description	d2	f _{max.±1}	f1	L	d	h	h1	h2	l	l1 max.	l2	l3	l4	F1 [N]*	F1 [N]#	F2 [N]*	F2 [N]#	⚖
36905	M.1053 P/30-295-AN-GR	30	295	37.5	324	8.5	68.5	50	17.5	42	268	75	56	27	1850	3400	2500	4000	231
36915	M.1053 P/30-345-AN-GR	30	345	37.5	374	8.5	68.5	50	17.5	42	318	75	56	27	1650	3150	2000	3300	249
36925	M.1053 P/30-395-AN-GR	30	395	37.5	424	8.5	68.5	50	17.5	42	368	75	56	27	1450	2600	1900	3000	266
36935	M.1053 P/30-495-AN-GR	30	495	37.5	524	8.5	68.5	50	17.5	42	468	75	56	27	1300	2000	1500	1900	301
36945	M.1053 P/30-595-AN-GR	30	595	37.5	624	8.5	68.5	50	17.5	42	568	75	56	27	1100	1900	1200	1800	336
36955	M.1053 P/30-695-AN-GR	30	695	37.5	724	8.5	68.5	50	17.5	42	668	75	56	27	1000	1600	1100	1500	371

M.1053-P-CLEAN

Code	Description	d2	f _{max.±1}	f1	L	d	h	h1	h2	l	l1 max.	l2	l3	l4	F1 [N]*	F1 [N]#	F2 [N]*	F2 [N]#	⚖
151481	M.1053 P/30-295-CLEAN	30	295	37.5	324	8.5	68.5	50	17.5	42	268	75	56	27	1850	3400	2500	4000	231
151483	M.1053 P/30-345-CLEAN	30	345	37.5	374	8.5	68.5	50	17.5	42	318	75	56	27	1650	3150	2000	3300	249
151485	M.1053 P/30-395-CLEAN	30	395	37.5	424	8.5	68.5	50	17.5	42	368	75	56	27	1450	2600	1900	3000	266
151487	M.1053 P/30-495-CLEAN	30	495	37.5	524	8.5	68.5	50	17.5	42	468	75	56	27	1300	2000	1500	1900	301
151489	M.1053 P/30-595-CLEAN	30	595	37.5	624	8.5	68.5	50	17.5	42	568	75	56	27	1100	1900	1200	1800	336
151491	M.1053 P/30-695-CLEAN	30	695	37.5	724	8.5	68.5	50	17.5	42	668	75	56	27	1000	1600	1100	1500	371

* Maximum working load # Load at breakage.

